

PROPRIETARY INFORMATION

THIS DRAWING AND SPECIFICATIONS ARE THE PROPERTY OF AIRPOT CORPORATION AND MAY NOT BE USED OR COPIED AS THE BASIS FOR MANUFACTURE OR SALE OF APPARATUS WITHOUT PERMISSION.

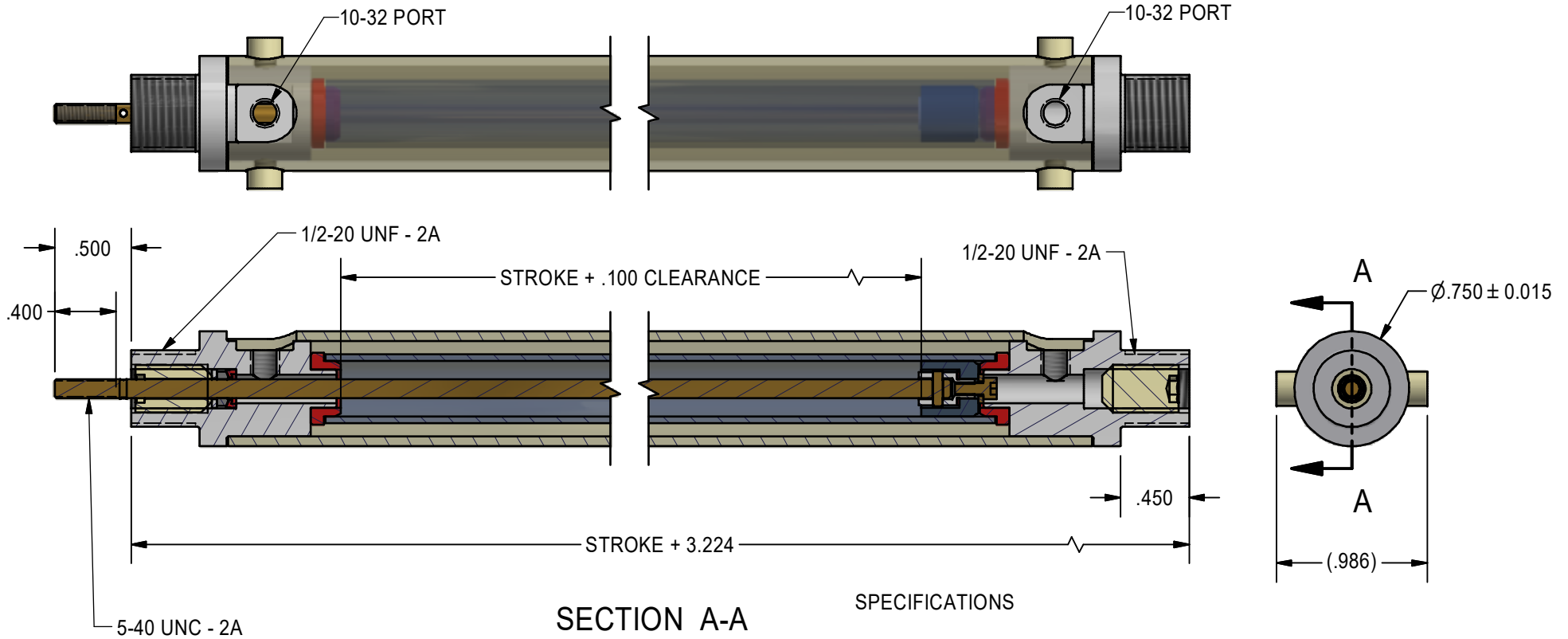

SECTION A-A

SPECIFICATIONS

1. Pressure Range: Full Vacuum to 50 psig  
0.34 MPa
2. Piston Area: .105 in<sup>2</sup> rear port (extend force), .093 in<sup>2</sup> front port (retract force)  
67.7 mm<sup>2</sup> rear port (extend force), 60 mm<sup>2</sup> front port (retract force)
3. Maximum output forces: 5.25 lbf (extend force), 4.65 lbf (retract force)  
23.3 N (extend force), 20.7 N (retract force)

MATERIALS LIST

BRASS  
BOROSILICATE GLASS  
CARBON GRAPHITE  
SILICONE RUBBER  
PLASTIC (VARIOUS)

PART NUMBER	STROKE
AC 13270-7	0.5 IN
AC 13270-4	2 IN
AC 13270-1	3 IN
AC 13270-2	4 IN
AC 13270-3	6 IN
AC 13270-8	7 IN
AC 13270-6	8 IN
AC 13270-5	12 IN

<b>Airpot</b> <sup>®</sup>		35 LOIS ST NORWALK CT 06851 US	203-846-2021 www.airpot.com
DRAWING NAME AIRPEL, MODEL E9 NON-MAGNETIC			DATE 24-MAR-08
SCALE 1:1	INITIALS TL	DRAWING NUMBER AC 13270-X-CUS	REV F